

# Reset Foamer

2-Part  
Concentrate  
Foamer

User Manual

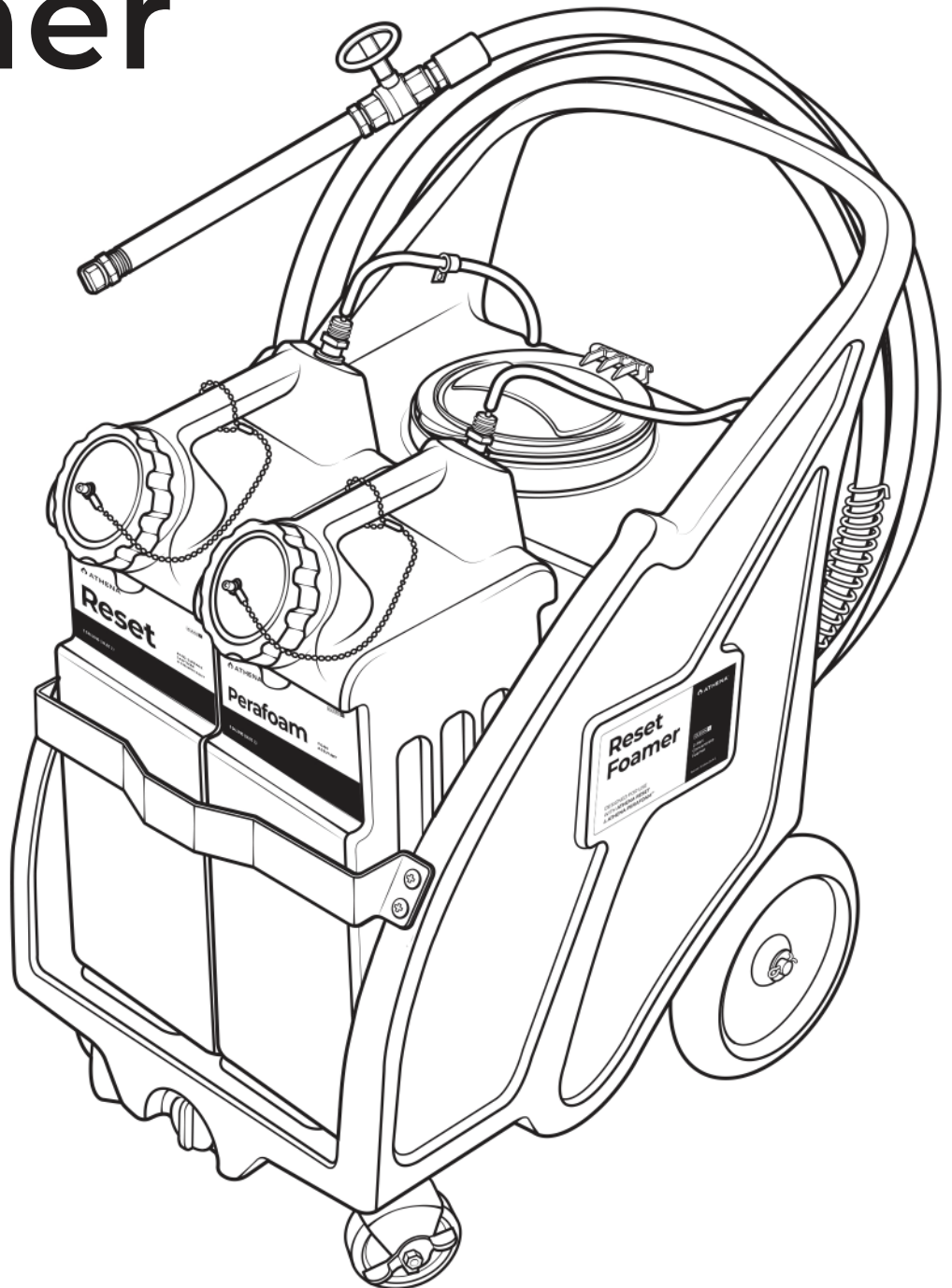

1-YEAR  
MANUFACTURER  
WARRANTY



READ ALL INSTRUCTIONS BEFORE USING, OR SERVICING, THIS EQUIPMENT. KEEP THIS MANUAL IN A LOCATION THAT IS READILY AVAILABLE TO USERS AND SERVICE TECHNICIANS.

English (Original Instructions)

# Contents

---

- 1. Safety ..... 3
  
- 2. Product Overview ..... 5
  - Product Requirements ..... 5
  - Product Specifications..... 5
  - Product Components..... 6
  
- 3. Operation ..... 8
  
- 4. Maintenance .....10
  
- 5. Troubleshooting ..... 11
  
- 6. Parts .....12
  
- 7. Warranty .....14

# 1. Safety

## WARNING

PEOPLE OR OBJECTS CAN BE HURT OR DAMAGED IF THIS UNIT IS NOT USED CORRECTLY!



Failure to read all the instructions before operating the unit may result in personal injury or death from the improper use or the chemical solution. Anyone handling, operating or using the unit must read, and understand, the instructions in the manual. The buyer assumes all responsibility for safety and proper use in accordance with the instructions.



Using, or servicing, the unit without proper protective clothing, gloves, and eye wear may result in serious injury such as burns, rashes, eye, throat or lung damage and death. Always wear protective clothing, gloves, and eye wear when using, or servicing, the unit. Protect eyes, skin, and lungs against drifting spray.



Chemical solutions may pose a health risk and death if they contact the skin or eyes, are inhaled or swallowed. Always read, and follow, all chemical safety precautions and handling instructions provided by the chemical manufacturer and the Safety Data Sheet (SDS) associated with the chemical solution being used before using the unit.



Pressure within the equipment may cause an unexpected release of the chemical solution and cause serious injury such as burns, rashes, eye damage, throat or lung damage and death. Always depressurize and clean the unit after each use. Release any remaining air pressure by twisting the pressure relief valve to the right ½ turn. Never leave the unit unattended while pressurized.

Using the unit with fluid temperatures above 100°F (37.77°C) may result in scalding, burns, serious injury or death. DO NOT use a solution with a temperature above 100°F (37.77°C).

Operating the unit when damaged or leaking may result in exposure to chemical solutions, serious injury or death. Never use the unit if it is damaged or leaking.

Never point the discharge wand at yourself, another person, or any object you do not want covered in chemical.



Using incoming air pressure exceeding 100 psi (7 bar) may result in pressure buildup, explosion, serious injury or death. DO NOT exceed 100 psi (7 bar) incoming air pressure when operating the unit.



Use of hydrocarbons and flammable products may result in explosions, fire and serious injury or death. Never use hydrocarbons or flammable products with the unit.

Mixing an alkaline with an acid may result in a chemical reaction. Overheating of the mixture may cause it to splatter caustic compounds or release hazardous fumes, gas and vapors. Always flush the unit with fresh water for five (5) minutes when switching from an alkaline to an acid or an acid to an alkaline.

## NOTICE

Servicing, or modification, of this unit with parts not listed in this manual may cause the unit to operate improperly. Do not use unauthorized parts when servicing the unit.

Use of an air lubricator before the unit may result in diminished performance and damage to the unit. Do not use an air lubricator before the unit.

Moisture in the air lines will damage the pump and diminish the pumps life. The air must be filtered, clean, dry and free of moisture. If needed, install an air dryer before the unit.

## PROTECT THE ENVIRONMENT



Please dispose of packaging materials, old machine components, and hazardous fluids in an environmentally safe way according to local waste disposal regulations.

# 2. Product Overview

---

## Product requirements

Compressed air requirements	50 psi with 5-10 SCFM (141-283 l/min)
Liquid temperature range	40-100°F (4.4-37°C)
Chemical compatibility	Chemical products used with this equipment must be formulated for this type of application and compatible with unit materials and pump seals. For more information on chemical compatibility, consult the manufacturer or SDS for your product or contact our customer service department.

## Product specifications

Power type	Compressed air
Chemical pickup type	Draws from concentrated product
Dilution ratio	1 oz (29.57 ml) of each chemical per 1 gallon (3.8 liters) of water
Number of products unit can draw from	Two products, simultaneously
Capacity	15 gallons (56.8 liters) of water 5 gallons (18.9 liters) of Athena® PERAFOAM 5 gallons (18.9 liters) of Athena® RESET
Discharge line length/diameter	50 ft. (15.2 m) hose, with 3/4 in. (19 mm) inside diameter
Discharge wand/tip type	10 in. (3.9 cm) stainless steel wand with 80 degree fan tip and ball valve
Pump seals	Kalrez
Wheel type	Two 10 in. (25.4 cm) non-marking wheels Two 5 in. (12.7 cm) casters—one with lock

# Product components

Before you begin, get to know the **Athena® Reset Foamer** components that you will need to use, adjust or assemble.

## Back plate assembly • Inside view

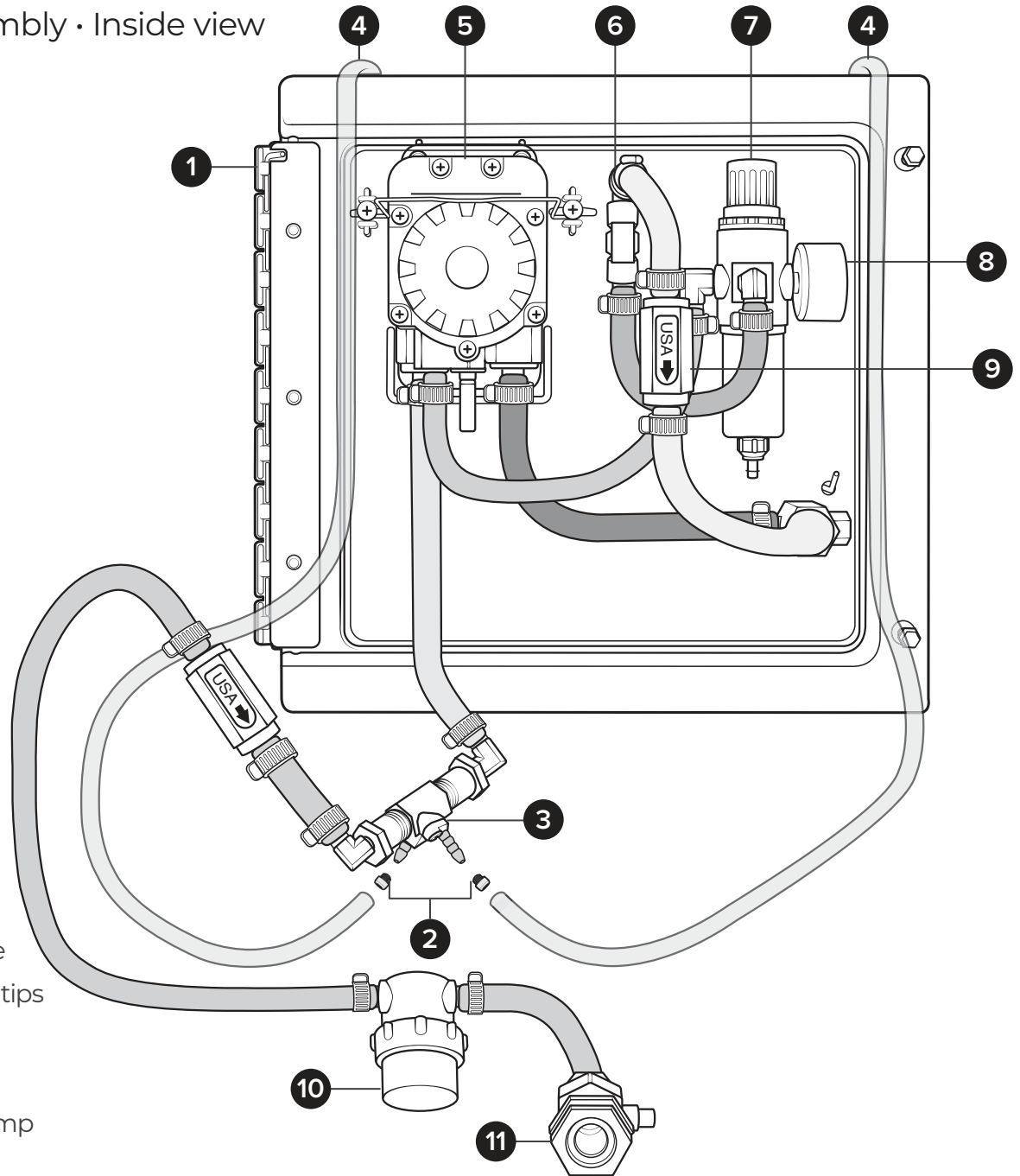

1. Hinged back plate
2. Orange metering tips
3. Dual injector
4. Suction lines
5. Quick change pump
6. Flow control valve (includes black knob)
7. Air regulator
8. Air pressure gauge
9. Check valves
10. In-line strainer
11. Suction line valve

Tank assembly • Front view

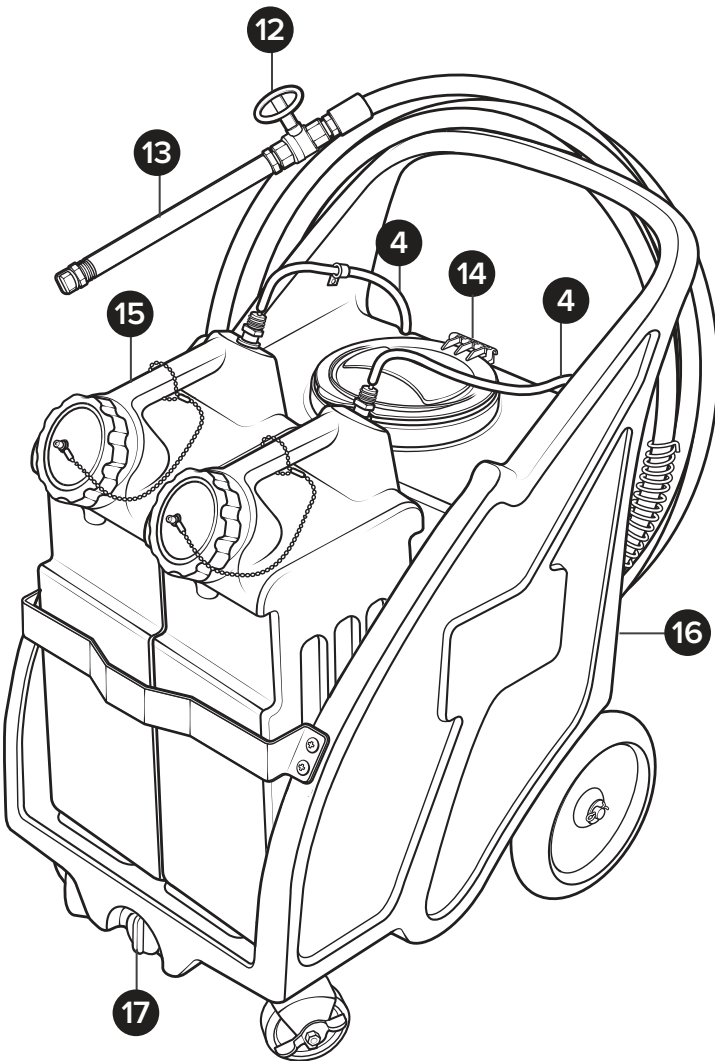

Tank assembly • Back view

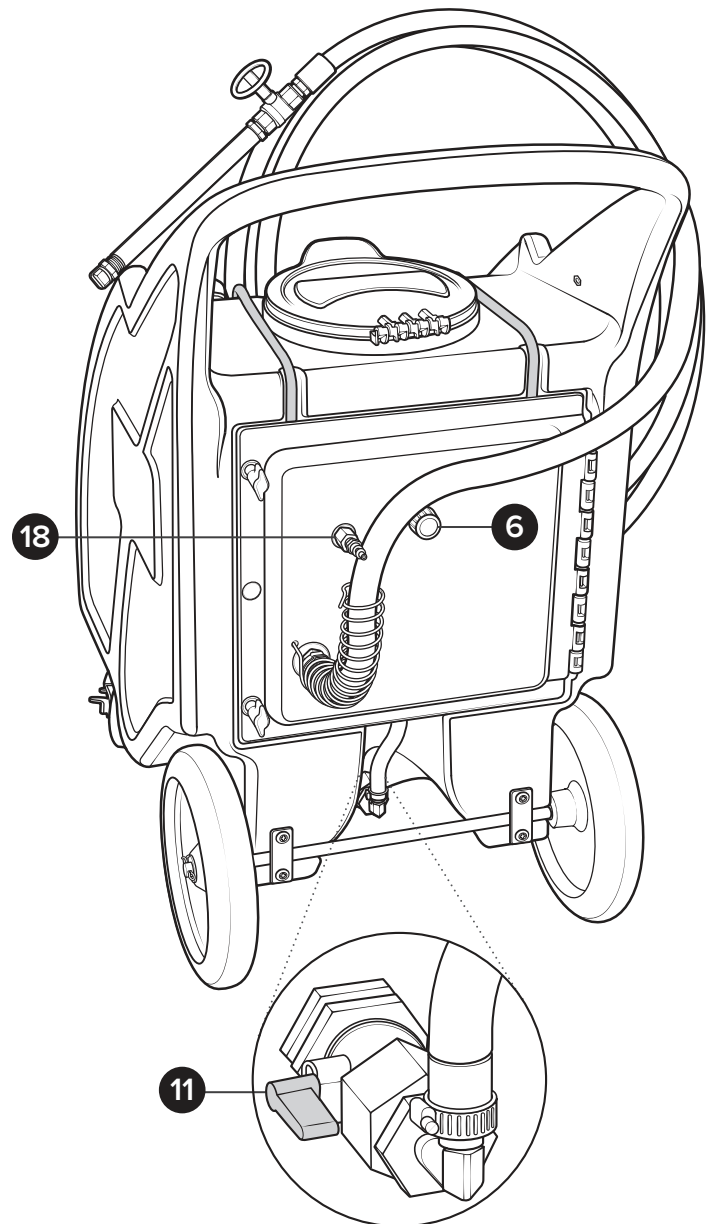

- 12. Discharge ball valve
- 13. Foam wand with spray tip
- 14. Hinged cap assembly
- 15. Chemical jug
- 16. Tank
- 17. Drain plug
- 18. Air fitting

# 3. Operation

1. Fill the tank with water.
2. Follow all instructions from chemical manufacturer. Fill the chemical container with chemical concentrate.
  - 2a. Fill Perafoam chemical container with Athena® Perafoam.
  - 2b. Fill Reset chemical container with Athena® Reset.
3. Connect each suction line to quick-connect fittings on 5 gallon chemical jugs.
4. Verify that the suction line valve at the base of the suction line is open, to allow fluid into the suction line.
5. With the discharge ball valve in the closed position, plug an air line into the air fitting.
6. Slowly open the discharge ball valve to begin foaming. The discharge ball valve should be completely open while foaming.
7. While the unit is running and discharging product, adjust the flow control valve as needed to regulate the wetness or dryness of the foam following the steps below:
  - a. Close needle valve completely in clockwise direction.
  - b. Open needle valve in counter-clockwise direction 3 complete turns.
  - c. Continue to open needle valve in  $\frac{1}{4}$  turn increments, allowing 30 seconds between adjustments, until desired consistency of foam is achieved.
8. Close the discharge ball valve to stop foaming.

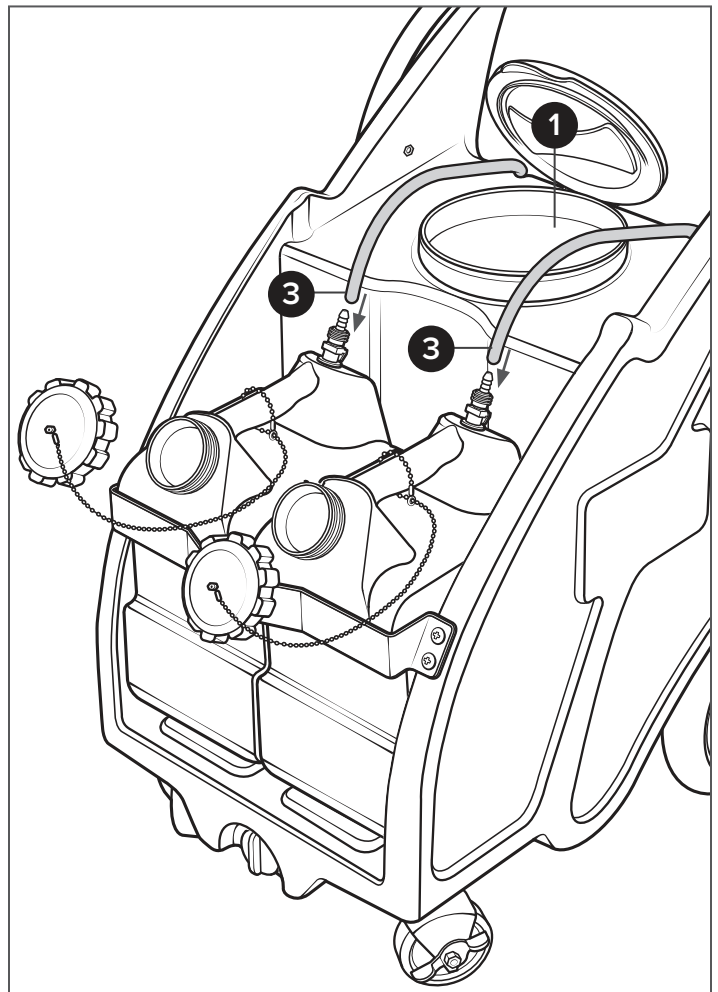
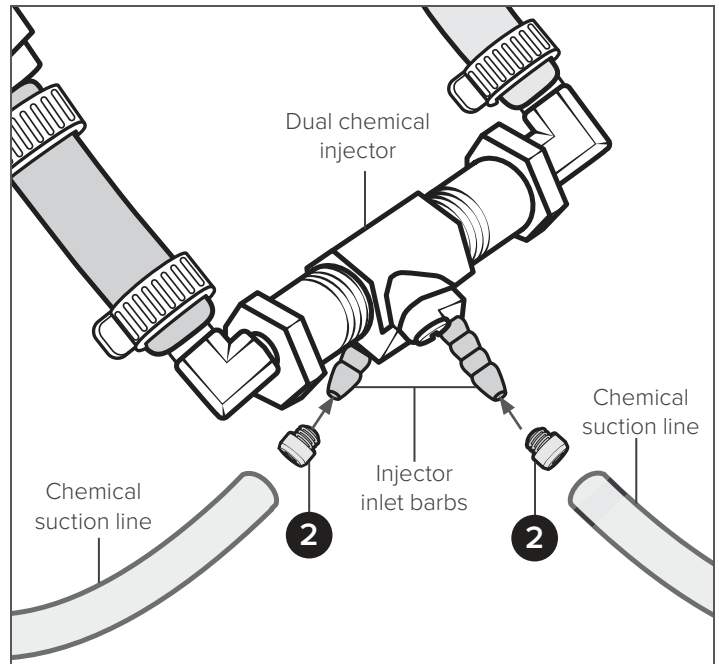



## After Use Instructions

11. Disconnect the chemical intake lines from the chemical containers and connect it to a container of clean water. Make sure that the unit tank still contains water.

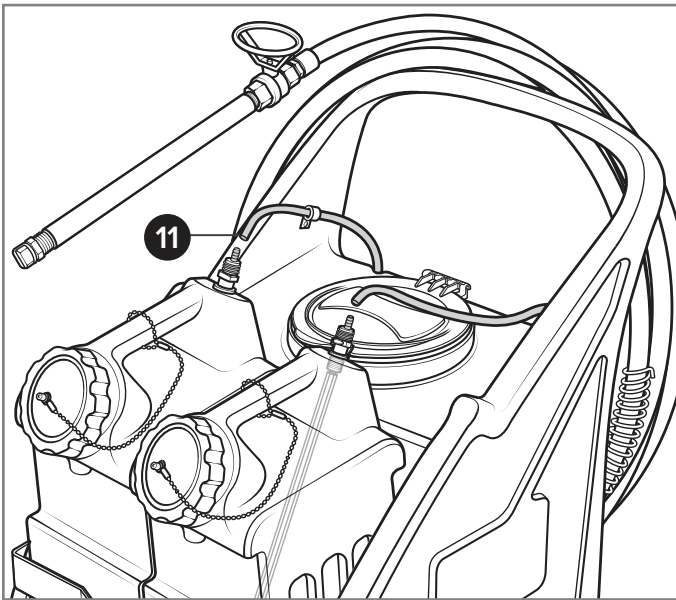

12. Activate the unit and allow it to run for 2-4 minutes, or until all chemical has been flushed from the system.
13. Disconnect the air line from the air fitting.
14. Open the discharge ball valve to relieve any pressure remaining in the system.
15. Close the ball valve after all pressure has been relieved from the system. Store the unit with the discharge ball valve in the closed position.

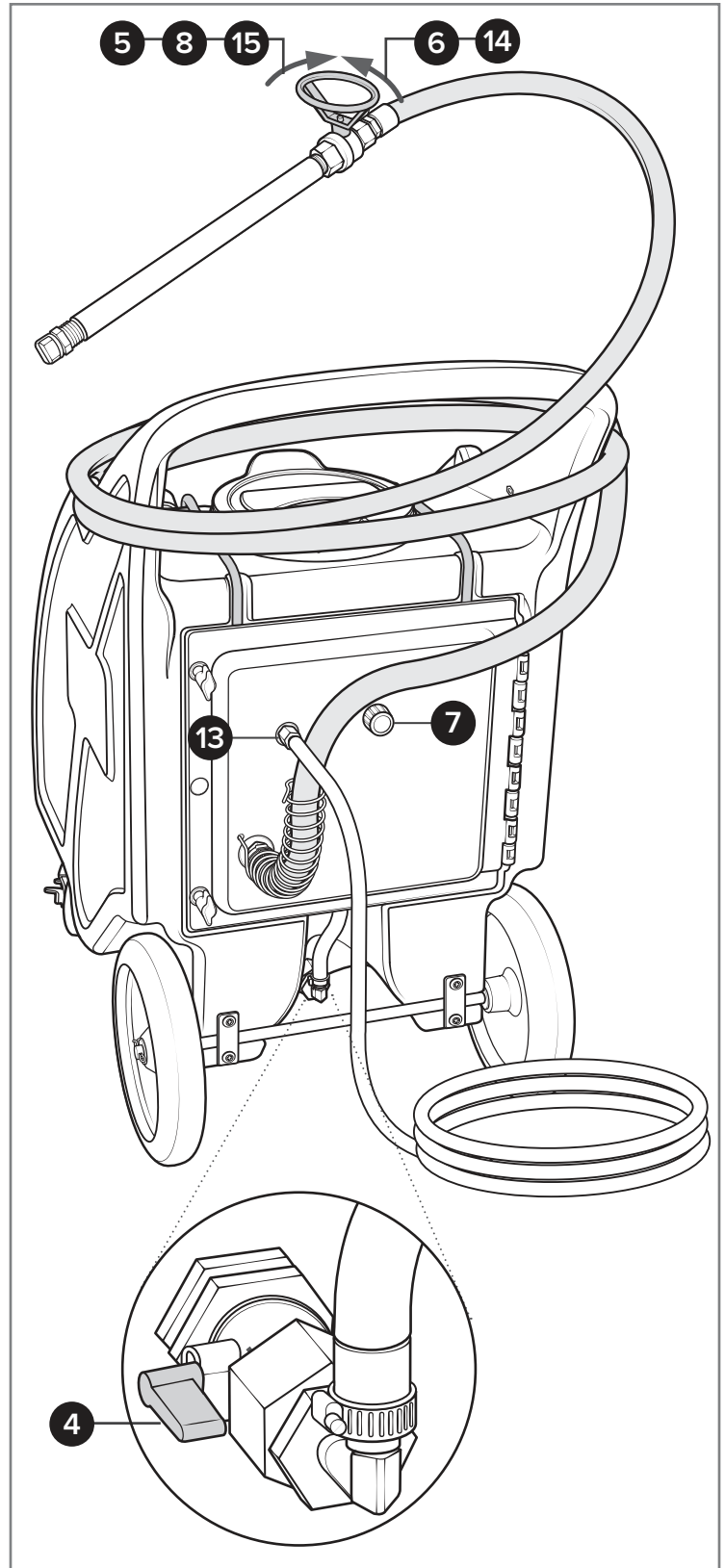

# 4. Maintenance

---

## **WARNING**

Performing any maintenance with the unit turned ON, plugged into an electrical power source and connected to the air and water supply may result in serious injury or death. Always ensure that the unit has been turned OFF, unplugged from the electrical power source, and disconnected from the air/water supply before conducting any maintenance.

## **NOTICE**

Servicing, or modification, of this unit with parts not listed in this manual may cause the unit to operate improperly. Do not use unauthorized parts when servicing the unit. Use of unauthorized parts will void the warranty.

To keep your foam unit operating properly, periodically perform the following maintenance procedures:

- Inspect the pump for wear and leaks.
- Inspect all hoses for leaks or excessive wear. Make sure all hose clamps and push-fittings are in good condition and properly secured.
- Replace the filter located within the air regulator as needed. Clean by unthreading the air regulator bowl from the air regulator.
- Check the chemical metering tip, suction line and strainer for debris and clean as needed.
- Drain your air compressor tank on a regular basis to help extend pump life. An air source with a high moisture content will accelerate pump wear.

Note: If your air source has a high moisture content, you may wish to install a water separator (item number WS-20CFM, sold separately) before the unit.

# 5. Troubleshooting

Issue	Solution
Air regulator bowl or air filter has debris such as water, oil, or rust particles	<ul style="list-style-type: none"> <li>• Clean by unthreading the air regulator bowl from the air regulator.</li> </ul>
Pump is cycling improperly due to lack of air pressure	<ul style="list-style-type: none"> <li>• The flow control valve is open too far. Close and readjust the flow control valve as described in the Operation section.</li> <li>• Ensure proper foaming chemical and concentration are being used.</li> </ul>
Air passes through the pump without cycling	<ul style="list-style-type: none"> <li>• The pump needs to be replaced.</li> </ul>
The solution backs up into the air regulator bowl	<ul style="list-style-type: none"> <li>• The check valve needs to be replaced.</li> </ul>
Foam comes out wet, no matter where the needle valve is positioned	<ul style="list-style-type: none"> <li>• Check for proper air pressure on the air gauge. The air regulator is factory set at 50 psi (3.4 bar). Operating range is 40 to 80 psi (3 to 5 bar) with 5 to 10 CFM (141.6 to 283.3 l/min).</li> <li>• The check valve may need to be replaced.</li> </ul>
The unit operates at a reduced pressure	<ul style="list-style-type: none"> <li>• Check the chemical metering tip, suction line and strainer for debris or damage. Clean or replace as needed. To prevent damage to the unit, the strainer must always be used.</li> <li>• Check the air compressor supplying the unit. If the pressure is less than 40 psi, turn the unit off until the compressor can catch up.</li> <li>• If the air supply is 50 psi (3.4 bar) or above, check the air gauge, which should read near 50 psi (3.4 bar). If the air gauge reads more or less than 50 psi (3.4 bar), adjust the pressure by turning the knob on the top of the air regulator.</li> <li>• Check if the stainless steel mixing mesh is plugged. Remove and clean it by following the instructions below:             <ol style="list-style-type: none"> <li>1. Be sure the foam unit is not plugged into an air supply and be sure to relieve all stored pressure in the unit by having the ball valve in the open position.</li> <li>2. Remove the stainless hose barb from the tee fitting.</li> <li>3. Remove the screen and the mixing mesh from inside the tee fitting.</li> <li>4. Clean any particles from the mixing mesh and the screen.</li> <li>5. Replace the mixing mesh and then the screen into the back of the tee and screw the stainless adaptor back into the tee. It is recommended to use a pipe thread sealant when reinstalling the stainless adaptor back into the tee fitting. If the mixing mesh has a lot of foreign particles in it, make sure the strainer is still in place.</li> </ol> </li> </ul>

# 6. Parts

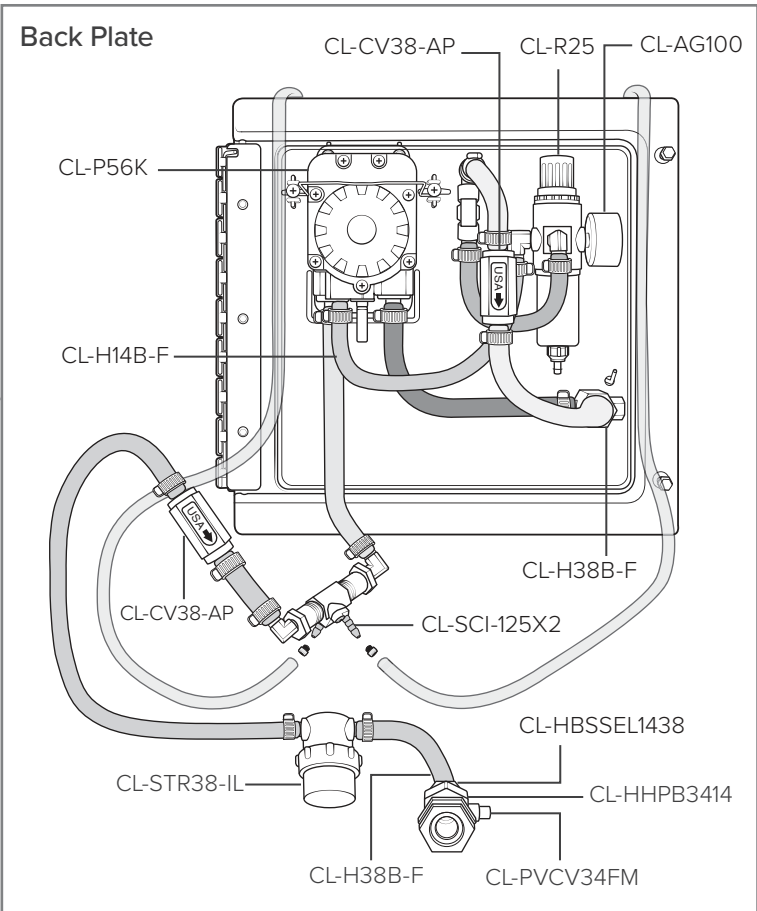
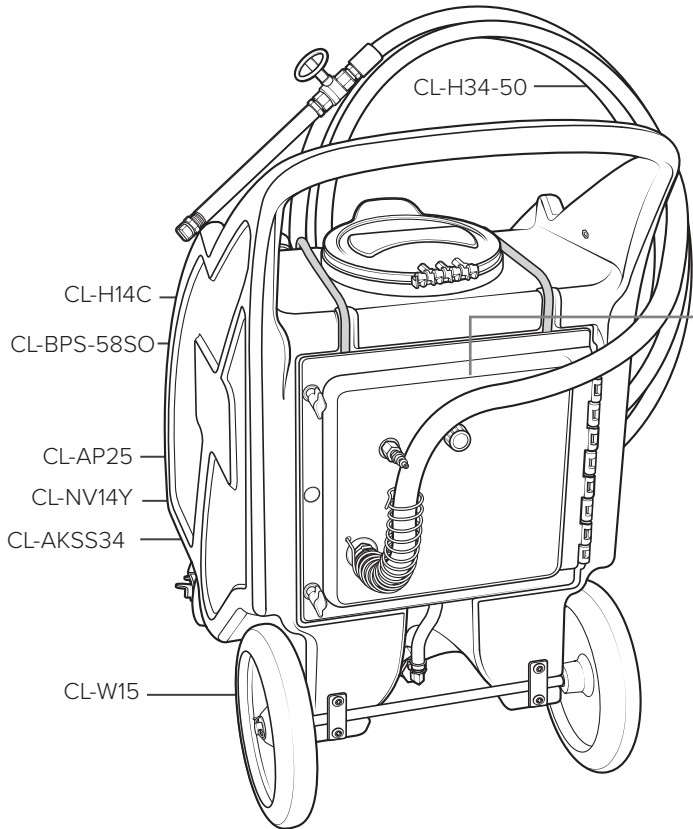
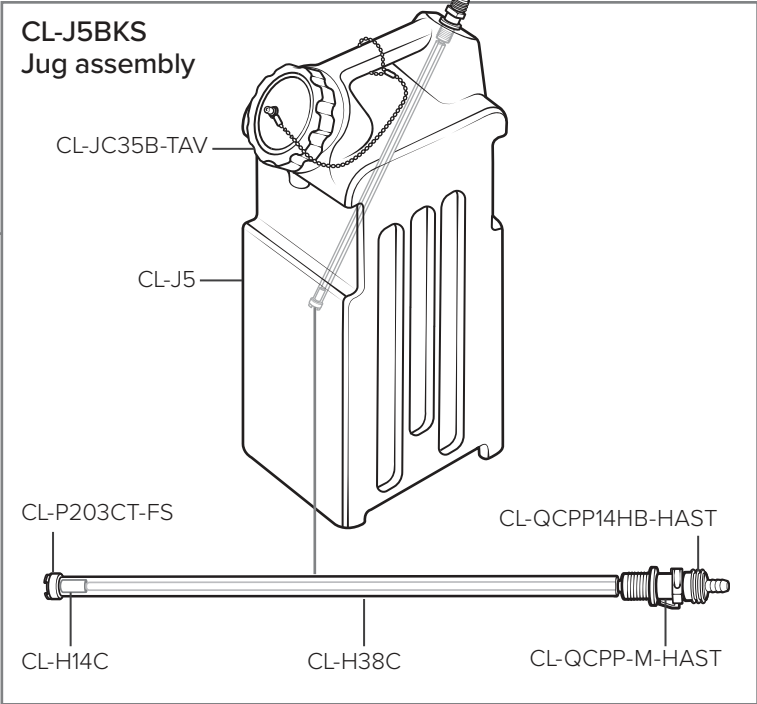
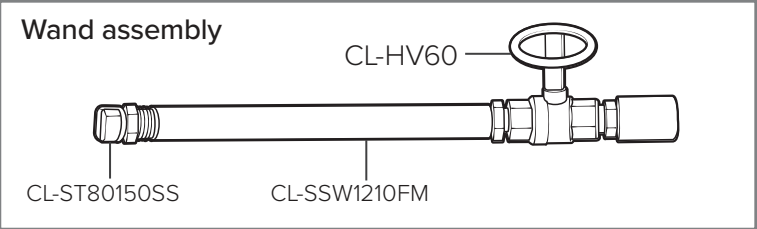
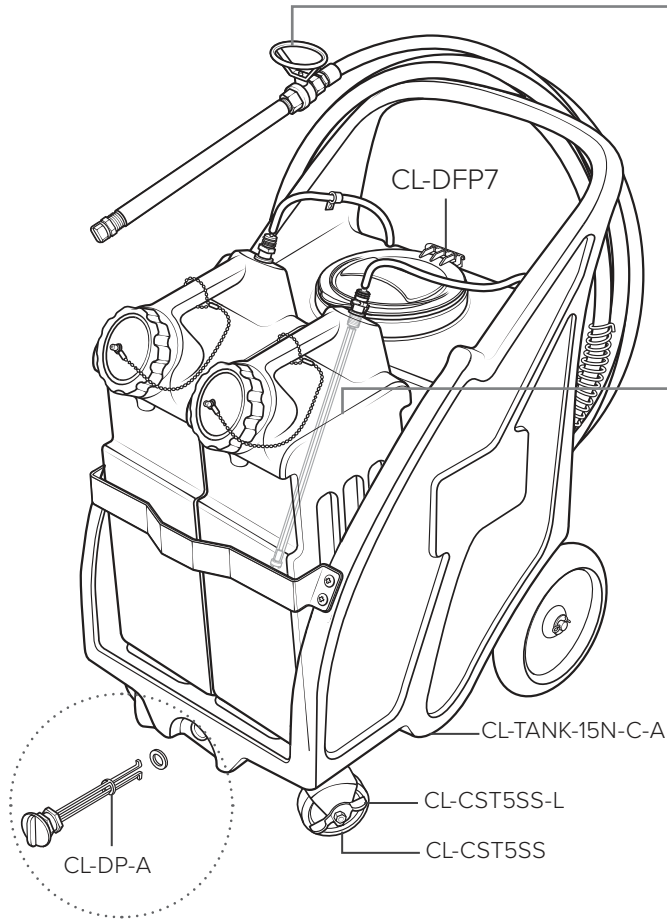

Item number	Description
CL-AG100	1.5 in. dry model 20 dual scale gauge
CL-AKSS34	SS anti-kink spring for 3/4 in. hose
CL-AP25	Air fitting 1/4 MPT x plug-brass
CL-CST5SS	5 in. S.S. Swivel caster with 4 in. wheel
CL-CST5SS-L	5 in. S.S. Swivel caster with 4 in. wheel and lock
CL-CV38-AP	White PVC check valve 3/8 barbs - Hastelloy spring - Teflon ball
CL-DFP7	7 in. hinged cap assembly - includes black cap, lid flange and hinge pin
CL-DP-A	Drain plug assembly for natural portable units - includes plug and gasket
CL-H14B-F	1/4 in. blue hose-hybrid TPE-available per ft.
CL-H14C	1/4 in. ID (3/8 in. OD) clear polyvinyl tubing - available per ft.
CL-H34-H34-50	H34-50 ft. of 3/4 in. replacement hose
CL-H38B-F	3/8 blue hose-hybrid TPE-available per ft.
CL-H38C	3/8 in. ID (1/2 in OD) clear PVC tubing - available per ft.
CL-HBSSEL1438	Stainless hose barb 1/4 MPT x 3/8 barb elbow
CL-HHPB3414	Hex head poly bushing 3/4 MPT x 1/4 FPT
CL-HV60	1/2 in. stainless ball valve - welded nut
CL-J5	5 Gallon natural jug
CL-J5BKS	5 Gallon natural jug-black cap-suction
CL-JC35B-TAV	Black 3.5 in. one way vented cap polypropylene-EPDM gasket and check valve-bead chain tether assembly
CL-NV14Y	Flow control valve - includes black knob
CL-Orange-tip	Orange metering tip for dema injector
CL-P203CT-FS	Foot strainer for the P203CT
CL-P56K	Pump with Kalrez seals - includes hose barbs, air fitting, and exhaust barb
CL-PV34FM	PVC valve 3/4 in. FPT x 3/4 in. MPT
CL-QCPP-M-HAST	3/8 in. panel mount socket - suction 3/8 ID x quick connect - Hastelloy spring - 11/16-24 thread
CL-QCPP14HB-HAST	1/4 in. in-line hose barb - polypro body - Hastelloy spring
CL-R25	Air regulator - 1/4 FPT two port 1/8 FPT two port - includes filter and bowl
CL-SCI-125X2	Stainless chemical injector-.125 Orifice-dual barb-3/8 MPT
CL-SSW1210FM	Polished - stainless wand-1/2 in. MPT x 1/2 in. FPT-10 in. long
CL-ST80150SS	Spray tip-80 degree-15.0 GPM-stainless-1/2 MPT
CL-STR38-IL	In-line strainer-3/8 barb-EPDM gasket-20 mesh SS
CL-TANK-15N-C-A	15 Gallon concentrate tank natural in color-assembly
CL-W15	Non-marking wheel for portable units
CL-WS-20CFM	Water Separator



# Reset Foamer

# WARRANTY

Warranty; Limitations. Athena warrants that the Reset Foamer and replacement parts (“Goods”) shall be free from defects in material and workmanship under proper and normal and recommended use for a period of 1 year from the date of shipment. Goods shall be considered defective only if a defect exists that materially impairs the value of the Goods to Customer and does not comply with Athena’s specifications (or, if none, does not comply with normal industry tolerances or standards). Goods shall not be defective if the Goods comply with Customer’s instructions or if the Goods have been modified, have been subject to misuse or neglect or if the Goods are not operated in a typical fashion. In accordance with the terms of this limited warranty (“Warranty”), Athena will, at its option, either replace any such defective Goods or parts thereof or issue Customer a credit for the purchase price of the defective Goods, provided that written notice of the defect is received by Athena within 30 days of the appearance of such defect and within the 1-year warranty period. If notice is not given by the required deadlines set forth in this paragraph, any claim for breach of warranty is waived and Athena shall not be liable. Upon receipt of notice of a possible defect in the Goods, Athena shall issue instructions for their disposition. No Goods shall be returned to Athena without its prior consent. Transportation charges for return and replacement under the Warranty will be borne by Athena if the Goods are defective. Under no circumstances will Athena’s liability exceed the purchase price of the defective Goods.

THE TERMS ABOVE SET FORTH CUSTOMER’S SOLE AND EXCLUSIVE REMEDY FOR ANY DEFECTIVE GOODS OR ANY BREACH OF WARRANTY. EXCEPT AS SET FORTH IN THE PARAGRAPH ABOVE, FOAMit MAKES NO WARRANTIES AS TO THE GOODS AND, IN PARTICULAR, MAKES NO WARRANTIES OF MERCHANTABILITY OR FITNESS FOR ANY PARTICULAR PURPOSE, AND CUSTOMER IS SOLELY RESPONSIBLE FOR DETERMINING THE PROPER APPLICATION AND USE OF THE GOODS. Athena shall have no tort liability to Customer with respect to any of the Goods and shall not be liable for consequential or incidental damages arising from any product defect, delay, nondelivery, recall or other breach. Customer shall have no right of rejection or of revocation of acceptance of the Goods.

**For technical support and troubleshooting please call or email:**

**(844) 333-1818**

**[support@athenaag.com](mailto:support@athenaag.com)**





The Perfect Run.™

Only use the Athena® Reset Foamer with Athena® Reset and Athena® Perafoam



## Athena® Reset

Hard Surface Sanitizer & Disinfectant

Used between runs

Kills bacteria, mold, fungus, and yeast

Non-foaming  
(unless used with Athena Perafoam)

EPA-registered peroxyacetic acid



## Athena® Perafoam

Foam Adjuvant

Easily get full coverage

 Warning:

Athena Reset and Athena Perafoam contain hazardous chemicals. Always use in accordance with instructions and wear appropriate personal protective equipment (PPE).



For usage and procedures, scan or visit the website:  
[www.AthenaAg.com](http://www.AthenaAg.com)



The Perfect Run.™

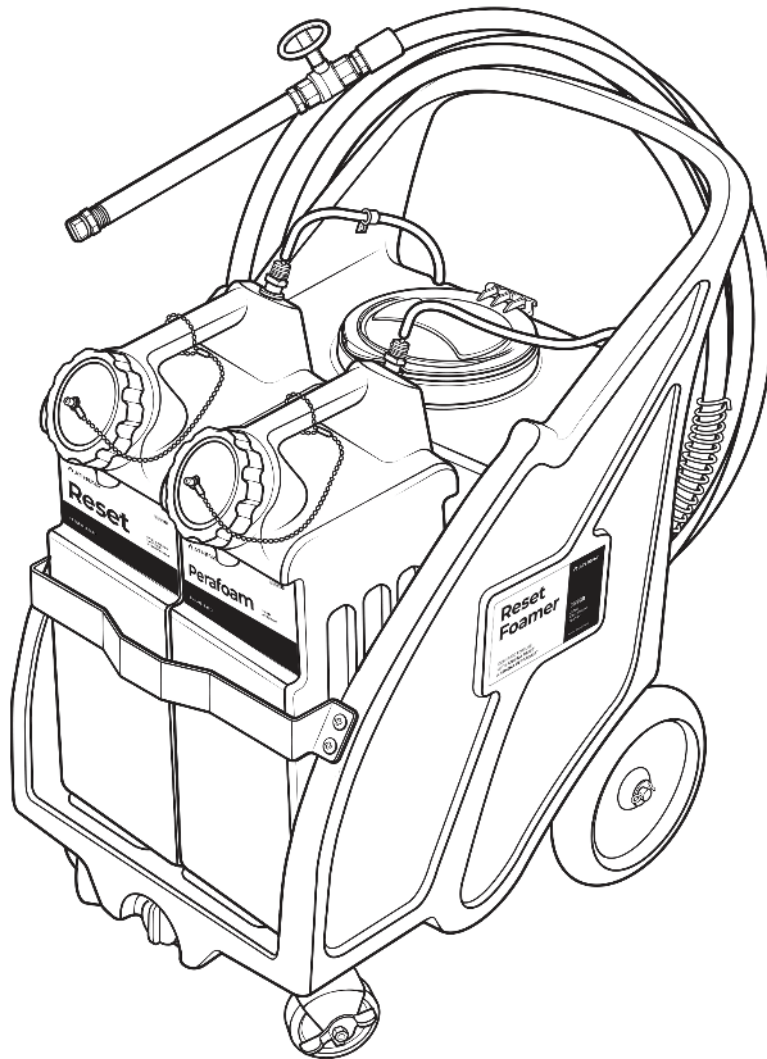

For usage and procedures, scan or visit the website:  
[www.AthenaAg.com](http://www.AthenaAg.com)

Athena® Reset Foamer  
CL-FOAM2-50